

VT Series

WIDE TEMPERATURE

寬溫品

- Operating with wide temperature range -40 ~ +105°C
適用於 -40 ~ +105°C 的寬溫範圍
- Load life of 2000 hours
負荷壽命 2000 小時
- Comply with the RoHS directive
符合 RoHS 指令



SPECIFICATIONS 特性表

Items 項目	Characteristics 主要特性																																																
Operation Temperature Range 使用溫度範圍	-40 ~ +105°C																																																
Voltage Range 額定工作電壓範圍	4 ~ 100V																																																
Capacitance Range 靜電容量範圍	0.1 ~ 6800μF																																																
Capacitance Tolerance 靜電容量允許偏差	±20% at 120Hz, 20°C																																																
Leakage Current 漏電流	Leakage current (∅4~∅10) ≦ 0.01CV or 3μA, whichever is greater (after 2 minutes application of rated voltage) Leakage current (∅12.5~∅16) ≦ 0.03CV or 4μA, whichever is greater (after 1 minute application of rated voltage) 漏電流 (∅4~∅10) ≦ 0.01CV 或 3μA, 取較大值 (施加額定工作電壓 2 分鐘後) 漏電流 (∅12.5~∅16) ≦ 0.03CV 或 4μA, 取較大值 (施加額定工作電壓 1 分鐘後)																																																
Dissipation Factor (tan δ) 損耗角正切	Measurement frequency 測試頻率: 120Hz, Temperature 溫度: 20°C <table border="1"> <thead> <tr> <th>Rated Voltage (V) 額定工作電壓</th> <th>4</th> <th>6.3</th> <th>10</th> <th>16</th> <th>25</th> <th>35</th> <th>50</th> <th>63</th> <th>100</th> </tr> </thead> <tbody> <tr> <td>tan δ (max.) 最大損耗角正切</td> <td>∅4~∅10 0.35</td> <td>0.30</td> <td>0.24</td> <td>0.20</td> <td>0.16</td> <td>0.14</td> <td>0.14</td> <td>0.12</td> <td>0.12</td> </tr> <tr> <td></td> <td>∅12.5~∅16 0.42</td> <td>0.38</td> <td>0.34</td> <td>0.30</td> <td>0.26</td> <td>0.22</td> <td>0.18</td> <td>0.14</td> <td>0.12</td> </tr> </tbody> </table>	Rated Voltage (V) 額定工作電壓	4	6.3	10	16	25	35	50	63	100	tan δ (max.) 最大損耗角正切	∅4~∅10 0.35	0.30	0.24	0.20	0.16	0.14	0.14	0.12	0.12		∅12.5~∅16 0.42	0.38	0.34	0.30	0.26	0.22	0.18	0.14	0.12																		
Rated Voltage (V) 額定工作電壓	4	6.3	10	16	25	35	50	63	100																																								
tan δ (max.) 最大損耗角正切	∅4~∅10 0.35	0.30	0.24	0.20	0.16	0.14	0.14	0.12	0.12																																								
	∅12.5~∅16 0.42	0.38	0.34	0.30	0.26	0.22	0.18	0.14	0.12																																								
Stability at Low Temperature 低溫特性	Measurement frequency 測試頻率: 120Hz <table border="1"> <thead> <tr> <th colspan="2">Rated Voltage (V) 額定工作電壓</th> <th>4</th> <th>6.3</th> <th>10</th> <th>16</th> <th>25</th> <th>35</th> <th>50~63</th> <th>100</th> </tr> </thead> <tbody> <tr> <td rowspan="2">Impedance Ratio 阻抗比 ZT/Z20 (max.)</td> <td>∅4~∅10</td> <td>Z(-25°C) / Z(20°C)</td> <td>7</td> <td>4</td> <td>3</td> <td>2</td> <td>2</td> <td>2</td> <td>3</td> </tr> <tr> <td>∅12.5~∅16</td> <td>Z(-40°C) / Z(20°C)</td> <td>15</td> <td>8</td> <td>6</td> <td>4</td> <td>4</td> <td>3</td> <td>4</td> </tr> <tr> <td rowspan="2"></td> <td>∅4~∅10</td> <td>Z(-25°C) / Z(20°C)</td> <td>7</td> <td>5</td> <td>4</td> <td>3</td> <td>2</td> <td>2</td> <td>2</td> </tr> <tr> <td>∅12.5~∅16</td> <td>Z(-40°C) / Z(20°C)</td> <td>17</td> <td>12</td> <td>10</td> <td>8</td> <td>5</td> <td>4</td> <td>3</td> </tr> </tbody> </table>	Rated Voltage (V) 額定工作電壓		4	6.3	10	16	25	35	50~63	100	Impedance Ratio 阻抗比 ZT/Z20 (max.)	∅4~∅10	Z(-25°C) / Z(20°C)	7	4	3	2	2	2	3	∅12.5~∅16	Z(-40°C) / Z(20°C)	15	8	6	4	4	3	4		∅4~∅10	Z(-25°C) / Z(20°C)	7	5	4	3	2	2	2	∅12.5~∅16	Z(-40°C) / Z(20°C)	17	12	10	8	5	4	3
Rated Voltage (V) 額定工作電壓		4	6.3	10	16	25	35	50~63	100																																								
Impedance Ratio 阻抗比 ZT/Z20 (max.)	∅4~∅10	Z(-25°C) / Z(20°C)	7	4	3	2	2	2	3																																								
	∅12.5~∅16	Z(-40°C) / Z(20°C)	15	8	6	4	4	3	4																																								
	∅4~∅10	Z(-25°C) / Z(20°C)	7	5	4	3	2	2	2																																								
	∅12.5~∅16	Z(-40°C) / Z(20°C)	17	12	10	8	5	4	3																																								
Load Life 高溫負荷特性	After 2000 hrs. (1000 hrs. for ∅4~∅6.3x5.4) application of the rated voltage at 105°C, they meet the characteristics listed below. 在 105°C 環境中施加額定工作電壓 2000 小時 (∅4~∅6.3x5.4 為 1000 小時) 後, 電容器的特性符合下表的要求。 <table border="1"> <tbody> <tr> <td>Capacitance Change 靜電容量變化率</td> <td>Within ±20% of initial value for capacitors of 10V or more (Within ±30% of initial value for capacitors of 4V or less) ≥10V 為初始值的±20%以內 (≤4V 為初始值的±30%以內)</td> </tr> <tr> <td>Dissipation Factor 損耗角正切</td> <td>200% or less of initial specified value 不大於規範值的 200%</td> </tr> <tr> <td>Leakage Current 漏電流</td> <td>initial specified value or less 不大於規範值</td> </tr> </tbody> </table>	Capacitance Change 靜電容量變化率	Within ±20% of initial value for capacitors of 10V or more (Within ±30% of initial value for capacitors of 4V or less) ≥10V 為初始值的±20%以內 (≤4V 為初始值的±30%以內)	Dissipation Factor 損耗角正切	200% or less of initial specified value 不大於規範值的 200%	Leakage Current 漏電流	initial specified value or less 不大於規範值																																										
Capacitance Change 靜電容量變化率	Within ±20% of initial value for capacitors of 10V or more (Within ±30% of initial value for capacitors of 4V or less) ≥10V 為初始值的±20%以內 (≤4V 為初始值的±30%以內)																																																
Dissipation Factor 損耗角正切	200% or less of initial specified value 不大於規範值的 200%																																																
Leakage Current 漏電流	initial specified value or less 不大於規範值																																																
Shelf Life 高溫貯存特性	After leaving capacitors under no load at 105°C for 1000 hours, they meet the specified value for load life characteristics listed above. 在 105°C 環境中無負荷放置 1000 小時後, 電容器的特性符合高溫負荷特性中所列的規定值。																																																
Resistance to Soldering Heat 耐焊接熱特性	After reflow soldering and restored at room temperature, they meet the characteristics listed below. 經過回流焊並冷卻至室溫後, 電容器的特性符合下表的要求。 <table border="1"> <tbody> <tr> <td>Capacitance Change 靜電容量變化率</td> <td>Within ±10% of initial value 初始值的±10%以內</td> </tr> <tr> <td>Dissipation Factor 損耗角正切</td> <td>initial specified value or less 不大於規範值</td> </tr> <tr> <td>Leakage Current 漏電流</td> <td>initial specified value or less 不大於規範值</td> </tr> </tbody> </table>	Capacitance Change 靜電容量變化率	Within ±10% of initial value 初始值的±10%以內	Dissipation Factor 損耗角正切	initial specified value or less 不大於規範值	Leakage Current 漏電流	initial specified value or less 不大於規範值																																										
Capacitance Change 靜電容量變化率	Within ±10% of initial value 初始值的±10%以內																																																
Dissipation Factor 損耗角正切	initial specified value or less 不大於規範值																																																
Leakage Current 漏電流	initial specified value or less 不大於規範值																																																
Humidity Life 恒濕特性	After leaving capacitors under no load at 85°C and 85% RH for 500 hours, they meet the specified value for resistance to soldering heat characteristics listed above. 在 85°C 與 85%RH 環境中無負荷放置 500 小時後, 電容器的特性符合耐焊接熱特性中所列的規定值。																																																
Storage 儲存	Storage conditions should be: Temperature: +5°C~+35°C; Humidity: lower than 75%; Place: indoor. 儲存環境應為: 溫度: +5°C~+35°C; 相對濕度 < 75%; 儲存場所: 室內。																																																
Working conditions 工作條件	Make sure that no higher than the rated voltage and temperature is applied the capacitor. 確認無超過額定電壓和額定溫度																																																
Marking 標示	Black print on the case top. 鉛殼頂部黑字印刷。																																																

DRAWING (Unit: mm) 外形圖

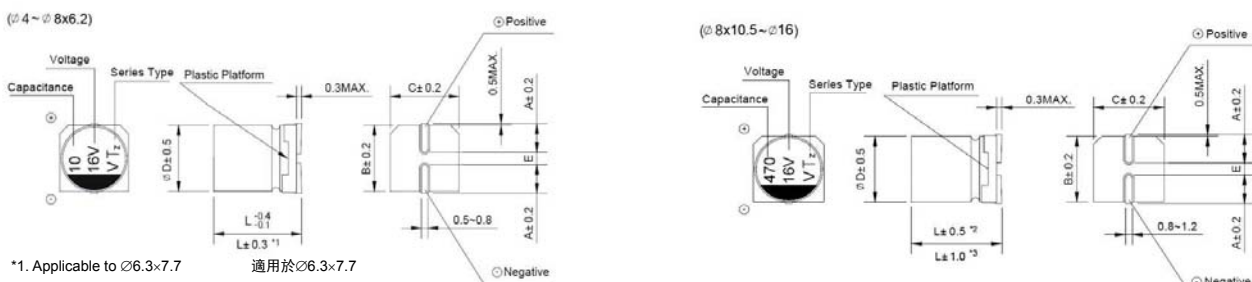

- *1. Applicable to ∅6.3x7.7 適用於 ∅6.3x7.7
- *2. Applicable to ∅8x10.5~∅10 適用於 ∅8x10.5~∅10
- *3. Applicable to ∅12.5~∅16 適用於 ∅12.5~∅16

NOTE: All designs and specifications are for reference only and are subject to change without prior notice. If any doubt about safety for your application, please contact us immediately for technical assistance before purchase.

注: 以上所提供的設計及特性參數僅供參考作用, 任何修改不預先通知。如果在使用上有疑問, 請在採購前與我們聯絡, 以便提供技術上的協助。



VT Series

□ DIMENSIONS (Unit: mm) 尺寸表

∅D x L	4 x 5.4	5 x 5.4	6.3 x 5.4	6.3 x 7.7	8 x 6.2	8 x 10.5	10 x 10.5	10 x 12.5	12.5 x 13.5	12.5 x 16	16 x 16.5
A	1.9	2.2	2.6	2.6	3.3	3.2	3.2	3.2	4.7	4.7	5.5
B	4.3	5.3	6.6	6.6	8.3	8.3	10.3	10.3	13.0	13.0	17.0
C	4.3	5.3	6.6	6.6	8.3	8.3	10.3	10.3	13.0	13.0	17.0
E ± 0.2	1.0	1.3	2.2	2.2	2.2	3.1	4.4	4.4	4.4	4.4	6.7
L	5.4	5.4	5.4	7.7	6.2	10.5	10.5	13.5	13.5	16.0	16.5

□ DIMENSIONS & MAXIMUM PERMISSIBLE RIPPLE CURRENT 規格尺寸及最大允許紋波電流

μF	WV Code 代碼	4		6.3		10		16		25	
		0G		0J		1A		1C		1E	
4.7	4R7					4 x 5.4	13	4 x 5.4	13	4 x 5.4	13
0.33	R33							4 x 5.4	13		
10	100					4 x 5.4	18	4 x 5.4	18	5 x 5.4 (4 x 5.4)	20 (14)
22	220			4 x 5.4	22	5 x 5.4 (4 x 5.4)	25 (20)	5 x 5.4 (4 x 5.4)	27 (20)	6.3 x 5.4 (5 x 5.4)	36 (25)
33	330	5 x 5.4 (4 x 5.4)	30 (18)	5 x 5.4 (4 x 5.4)	27 (22)	5 x 5.4 (4 x 5.4)	30 (22)	6.3 x 5.4 (5 x 5.4)	40 (28)	6.3 x 5.4 (5 x 5.4)	44 (29)
47	470	5 x 5.4 (4 x 5.4)	36 (24)	5 x 5.4 (4 x 5.4)	33 (25)	6.3 x 5.4 (5 x 5.4)	41 (30)	6.3 x 5.4 (5 x 5.4)	48 (31)	6.3 x 5.4 (8 x 6.2)	48 (91)
100	101	6.3 x 5.4 (5 x 5.4)	60 (43)	6.3 x 5.4 (5 x 5.4)	50 (39)	5 x 5.4 6.3 x 5.4 (8 x 6.2)	39 (53) (110)	6.3 x 5.4 (8 x 6.2)	60 (120)	6.3 x 7.7	91
150	151	6.3 x 5.4	52	6.3 x 5.4	55	6.3 x 5.4	62	6.3 x 7.7	95	8 x 10.5 (6.3 x 7.7)	140 (100)
220	221	6.3 x 5.4	57	6.3 x 7.7 (6.3 x 5.4)	105 (67)	6.3 x 5.4 6.3 x 7.7 (8 x 6.2)	85 105 (105)	8 x 10.5 (6.3 x 7.7) (8 x 6.2)	150 (105) (85)	8 x 10.5	175
330	331	6.3 x 7.7	100	6.3 x 7.7	105	8 x 10.5	196	8 x 10.5	195	10 x 10.5 (8 x 10.5)	240 (220)
470	471	6.3 x 7.7	105	8 x 10.5 (6.3 x 7.7)	210 (120)	10 x 10.5 (8 x 10.5)	260 (210)	10 x 10.5 (8 x 10.5)	295 (230)	10 x 10.5	280
560	561									10 x 10.5	320
680	681	8 x 10.5	210	8 x 10.5	210	10 x 10.5	270	10 x 10.5	315	10 x 12.5	400
1000	102	8 x 10.5	230	10 x 10.5 (8 x 10.5)	300 (230)	10 x 10.5	315	12.5 x 13.5 (10 x 12.5) (10 x 10.5)	500 (390) (340)	12.5 x 13.5	580
1500	152	10 x 10.5	315	10 x 12.5 (10 x 10.5)	450 (315)	10 x 12.5	460	12.5 x 13.5	550	12.5 x 16	850
2200	222	10 x 12.5 (10 x 10.5)	440 (340)	12.5 x 13.5 (10 x 12.5)	620 (500)	12.5 x 13.5	680	16 x 16.5 (12.5 x 16)	950 (750)	16 x 16.5	1050
3300	332	10 x 12.5	490	12.5 x 16 (12.5 x 13.5)	700 (660)	16 x 16.5	1000	16 x 16.5	1000		
4700	472	12.5 x 13.5	600	16 x 16.5	1000					Case size 尺寸	Ripple current 紋波電流
6800	682	16 x 16.5 (12.5 x 16)	950 (650)								

•Case size ∅DxL(mm), ripple current (mA rms) at 105°C 120Hz •尺寸∅DxL(mm), 紋波電流(mA rms)於 105°C 120Hz

NOTE: All designs and specifications are for reference only and are subject to change without prior notice. If any doubt about safety for your application, please contact us immediately for technical assistance before purchase.

注：以上所提供的設計及特性參數僅供參考，任何修改不作預先通知。如果在使用上有疑問，請在採購前與我們聯繫，以便提供技術上的協助。



CHIP TYPE 貼片式 VT

□ DIMENSIONS & MAXIMUM PERMISSIBLE RIPPLE CURRENT 規格尺寸及最大允許紋波電流

WV Code 代碼	μF	35		50		63		100	
		1V		1H		1J		2A	
0R1	0.1			4 × 5.4	0.7	4 × 5.4	0.7		
R22	0.22			4 × 5.4	1.6	4 × 5.4	1.6		
R33	0.33			4 × 5.4	2.5	4 × 5.4	2.5		
R47	0.47			4 × 5.4	3.5	4 × 5.4	3.5		
010	1			4 × 5.4	7	4 × 5.4	7	4 × 5.4	7
2R2	2.2			4 × 5.4	11	4 × 5.4	11	6.3 × 5.4	14
3R3	3.3	4 × 5.4	13	4 × 5.4	13	5 × 5.4	13	6.3 × 7.7 (6.3 × 5.4) (8 × 6.2)	32 (20) (30)
4R7	4.7	4 × 5.4	14	5 × 5.4 (4 × 5.4)	16 (13)	5 × 5.4	16	6.3 × 7.7 (6.3 × 5.4)	35 (21)
100	10	5 × 5.4 (4 × 5.4)	21 (14)	6.3 × 5.4	24	6.3 × 7.7 (6.3 × 5.4) (8 × 6.2)	39 (24) (25)	8 × 10.5 (6.3 × 7.7)	77 (35)
220	22	6.3 × 5.4	38	6.3 × 7.7 (6.3 × 5.4) (8 × 6.2)	51 (42) (70)	8 × 10.5 (6.3 × 7.7)	98 (49)	10 × 10.5 (8 × 10.5)	126 (84)
330	33	6.3 × 5.4 (8 × 6.2)	42 (84)	6.3 × 7.7	60	8 × 10.5	112	10 × 10.5	133
470	47	6.3 × 7.7 (6.3 × 5.4)	70 (50)	8 × 10.5 (6.3 × 7.7)	120 (63)	10 × 10.5 (8 × 10.5)	160 (119)	12.5 × 13.5 (10 × 12.5) (10 × 10.5)	250 (160) (140)
470	56					10 × 10.5 (8 × 10.5)	165 (120)		
680	68	4 × 5.4	13					12.5 × 13.5 (10 × 12.5)	300 (180)
								Case size 尺寸	Ripple current 紋波電流

WV Code 代碼	μF	35		50		63		100	
		1V		1H		1J		2A	
101	100	8 × 10.5 (6.3 × 7.7)	120 (84)	10 × 10.5 (8 × 10.5)	170 (140)	12.5 × 13.5 (10 × 12.5) (10 × 10.5)	270 (210) (196)	16 × 16.5 (12.5 × 13.5)	450 (380)
151	150	8 × 10.5	155	10 × 10.5	170	10 × 12.5	225		
221	220	10 × 10.5 (8 × 10.5)	220 (190)	10 × 12.5 (10 × 10.5)	280 (220)	16 × 16.5 (12.5 × 13.5)	560 (470) (235)	16 × 16.5	550
331	330	10 × 10.5	245	16 × 16.5 (12.5 × 13.5) (10 × 12.5)	600 (420) (295)	16 × 16.5 (12.5 × 16)	700 (510)		
471	470	12.5 × 13.5 (10 × 12.5) (10 × 10.5)	520 (375) (280)	16 × 16.5 (12.5 × 16)	700 (420)	16 × 16.5	750		
681	680	12.5 × 13.5 (10 × 12.5)	530 (395)	16 × 16.5	750			Case size 尺寸	Ripple current 紋波電流
102	1000	16 × 16.5 (12.5 × 16)	750 (600)						

•Case size $\varnothing D \times L$ (mm), ripple current (mA rms) at 85°C 120Hz •尺寸 $\varnothing D \times L$ (mm), 紋波電流(mA rms)於 85°C 120Hz

□ FREQUENCY COEFFICIENT OF ALLOWABLE RIPPLE CURRENT 紋波電流頻率補償系數

Frequency 頻率		50Hz	120Hz	300Hz	1KHz	10KHz~
Coefficient 系數	$\varnothing 4 \sim \varnothing 10$	0.1 ~ 68μF	0.70	1.00	1.17	1.36
		100 ~ 3300μF	0.85	1.00	1.08	1.20
	$\varnothing 12.5 \sim \varnothing 16$	~ 68μF	0.75	1.00	1.35	1.57
		100 ~ 680μF	0.80	1.00	1.23	1.34
		1000 ~ 6800μF	0.85	1.00	1.10	1.13

● Taping specifications are given in page 10. 編帶標準請參閱第 10 頁。

● Please refer to page 11 for the minimum package quantity. 最小包裝數量請參閱第 11 頁。

NOTE: All designs and specifications are for reference only and are subject to change without prior notice. If any doubt about safety for your application, please contact us immediately for technical assistance before purchase.

注：以上所提供的設計及特性參數僅供參考，任何修改不作預先通知。如果在使用上有疑問，請在採購前與我們聯繫，以便提供技術上的協助。



STANDARD OF VT SERIES CAPACITORS**1. Scope**

This Specification covers "VT Series" V-chip aluminum electrolytic capacitors.

2. Reference Standard

Japanese industrial Standard JIS C-5141 characteristics W and JIS C-5101 except as specified in this specification.

3. Environmental Protection Standard

Comply with the EU directive 2011/65/EC;

4. Operating Temperature Range

-40°C ~ +105°C

5. Voltage Range

4 ~ 100V

6. Capacitance Range

0.1 ~ 6800μF

7. Capacitance Tolerance

±20% at 120Hz, 20°C

8. Leakage Current

Leakage current (Ø4~Ø10) \cong 0.01CV or 3μA, whichever is greater (after 2 minutes application of rated voltage)

Leakage current (Ø12.5~Ø16) \cong 0.03CV or 4μA, whichever is greater (after 1 minute application of rated voltage)

9. Tan δ

Measurement frequency: 120Hz, Temperature: 20°C

Rated Voltage (V)		4	6.3	10	16	25	35	50	63	100
Tan δ (max.)	Ø4~Ø10	0.35	0.30	0.24	0.20	0.16	0.14	0.14	0.12	0.12
	Ø12.5~Ø16	0.42	0.38	0.34	0.30	0.26	0.22	0.18	0.14	0.12

10. Stability at Low Temperature

Measurement frequency: 120Hz

Rated Voltage (V)			4	6.3	10	16	25	35	50~63	100
Impedance Ratio ZT/Z20 (max.)	Ø4~Ø10	Z(-25°C) / Z(20°C)	7	4	3	2	2	2	2	3
		Z(-40°C) / Z(20°C)	15	8	6	4	4	3	3	4
	Ø12.5~Ø16	Z(-25°C) / Z(20°C)	7	5	4	3	2	2	2	2
		Z(-40°C) / Z(20°C)	17	12	10	8	5	4	3	3

11. Load Life

After 2000 hrs.(1000 hrs. for Ø4~Ø6.3×5.4) application of the rated voltage at 105°C, they meet the characteristics listed below.

Capacitance Change	Within ±20% of initial value for capacitors of 10V or more (Within ±30% of initial value for capacitors of 4V or less)
Tan δ	200% or less of initial specified value
Leakage Current	Initial specified value or less

12. Self Life

After leaving capacitors under no load at 105°C for 1000 hours, they meet the specified value for load life characteristics listed above.

13. Resistance to Soldering Heat

After reflow soldering and restored at room temperature, they meet the characteristics listed below.

Capacitance Change	Within $\pm 10\%$ of initial value
Tan δ	Initial specified value or less
Leakage Current	Initial specified value or less

14. Surge Voltage

The surge voltage rating is the maximum DC over-voltage to which the capacitors may be subject of short periods not exceeding approximately 30 seconds at infrequent intervals of not less than 5 minutes. The rated surges of the electrolytic capacitors are as follows:

Rated voltage (V)	6.3	10	16	25	35	50	63	100
Surge voltage (V)	7.3	11.5	18.4	28.8	40.3	57.5	72.5	115

15. Marking and drawing (Unit: mm)

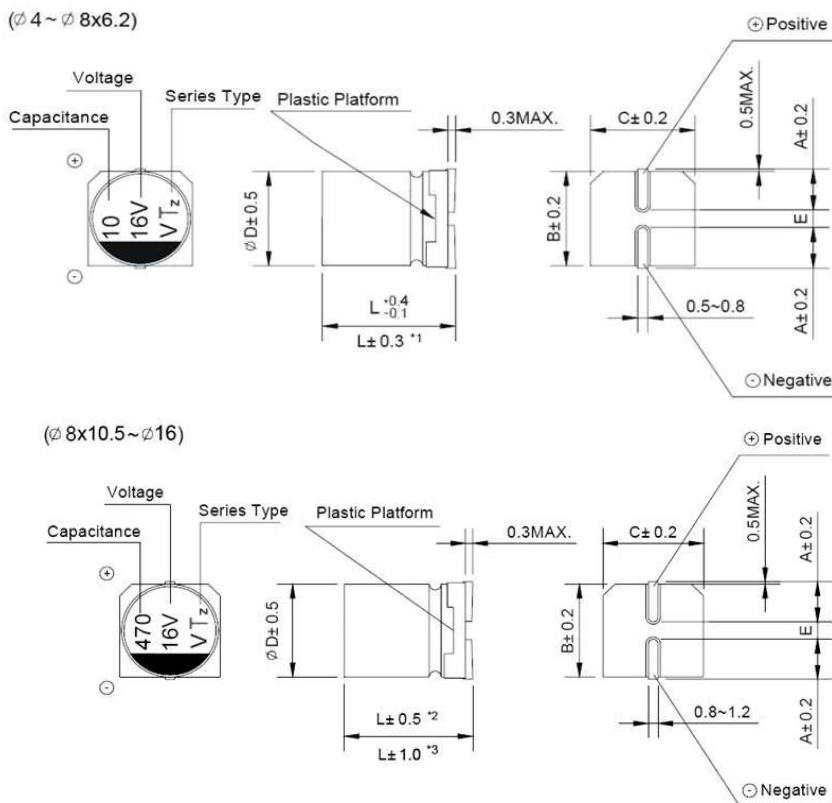

*1. Applicable to $\phi 6.3 \times 7.7$
 *2. Applicable to $\phi 8 \times 10.5 \sim \phi 10$
 *3. Applicable to $\phi 12.5 \sim \phi 16$

16. Dimensions (Unit: mm)

$\phi D \times L$	4 x 5.4	5 x 5.4	6.3 x 5.4	6.3 x 7.7	8 x 6.2	8 x 10.5	10 x 10.5	10 x 12.5	12.5 x 13.5	12.5 x 16	16 x 16.5
A	2.0	2.2	2.6	2.6	3.3	3.0	3.2	3.2	4.6	4.6	5.8
B	4.3	5.3	6.6	6.6	8.3	8.3	10.3	10.3	12.8	12.8	17.0
C	4.3	5.3	6.6	6.6	8.3	8.3	10.3	10.3	12.8	12.8	17.0
$E \pm 0.2$	1.0	1.5	2.1	2.1	2.2	3.1	4.6	4.6	4.6	4.6	6.4
L	5.4	5.4	5.4	7.7	6.2	10.5	10.5	13.5	13.5	16.0	16.5

17. Taping Specifications

■ Carrier Tape

● Drawing 1 (for $\varnothing 4 \sim \varnothing 10$)

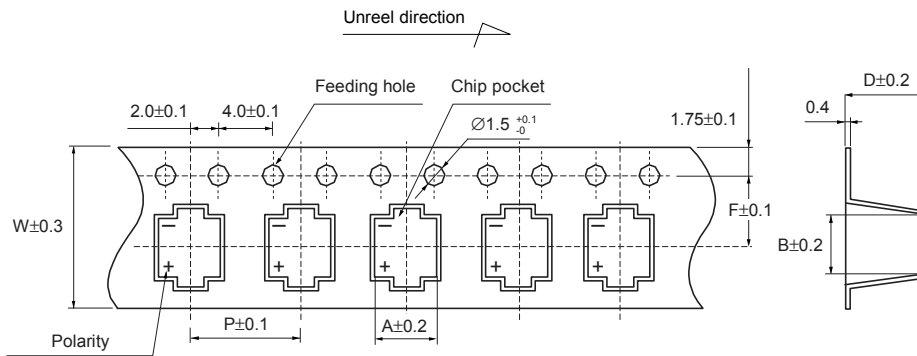

Dimension

(Unit: mm)

$\varnothing D \times L$	4×5.4/5.8	5×5.4/5.8	6.3×5.4/5.8	6.3×7.7/10.5	8×6.2	8×10.5/12.5	10×10.5/12.5/13.5
W	12.0	12.0	16.0	16.0	16.0	24.0	24.0
P	8.0	12.0	12.0	12.0	12.0	16.0	16.0
F	5.5	5.5	7.5	7.5	7.5	11.5	11.5
A	5.0	6.0	7.0	7.0	8.7	8.7	10.7
B	5.0	6.0	7.0	7.0	8.7	8.7	10.7
D	6.2	6.2	6.2	8.4/11.0	6.8	11.0/13.2	11.0/13.2/14.0

● Drawing 2 (for $\varnothing 12.5 \sim \varnothing 16$)

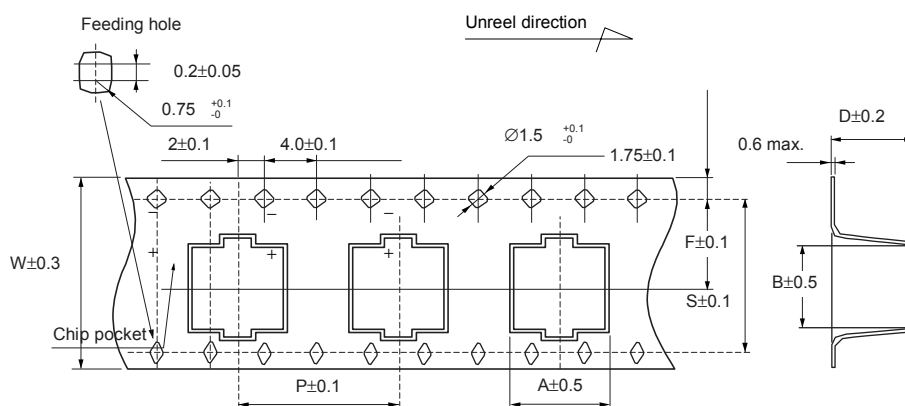

Dimension

(Unit: mm)

$\varnothing D \times L$	12.5×13.5	12.5×16	16×16.5
W	32.0	32.0	44.0
P	24.0	24.0	28.0
F	14.2	14.2	20.2
A	14.0	14.0	17.5
B	14.0	14.0	17.5
D	14.0	16.5	17.5
S	28.4	28.4	40.4

■ Reel

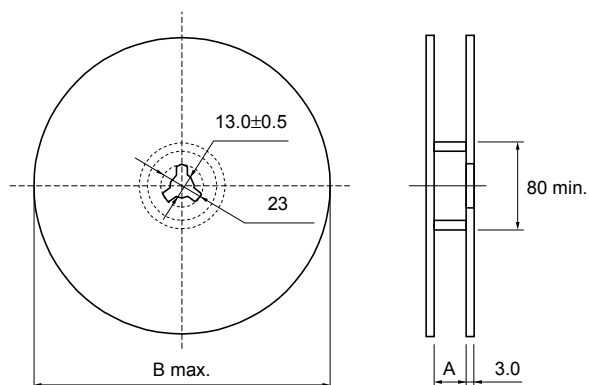

(Unit: mm)

∅D × L	4×5.4/5.8	5×5.4/5.8	6.3×5.4 /5.8/7.7/10.5/11.5	8×6.2	8×10.5/12.5	10×10.5/12.5	12.5×13.5/16	16×16.5
A	14	14	18	18	26	26	34	46
B	382	382	382	382	382	382/332	382/332*	332*

*For a small package

■ box

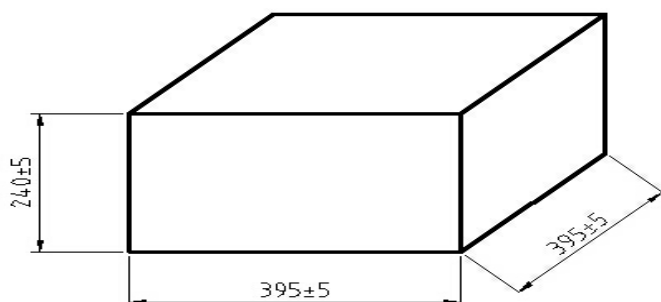

■ Package Quantity

Size ∅D×L (mm)	Reel (pcs)	In-box (reels)	Quantity/In-box (pcs)
4 × 5.4/5.8	2,000	12	24,000
5 × 5.4/5.8	1,000	12	12,000
6.3 × 5.4/5.8	1,000	10	10,000
6.3 × 7.7	1,000	10	10,000
6.3 × 10.5	750	10	7,500
8 × 6.2	1,000	10	10,000
8 × 10.5	500	7	3,500
8 × 12.5	500	7	3,500
10 × 10.5	500	7	3,500
10 × 12.5	450	7	3,150
12.5 × 13.5	250	6	1,500
12.5 × 16	200	6	1,200
16 × 16.5	150	4	600

*For a small package

18. Lead-free Reflow Soldering Condition

A. Recommended Conditions for Reflow Soldering

- (1) A thermal condition system such as infrared radiation (IR) or hot blast should be adopted, and vapor heat transfer systems (VPS) are not recommended.
- (2) Reflow soldering should be within 2 cycles. Please make sure that the parts have enough cooling time.
- (3) For lead-free type reflow soldering, please observe proper conditions below:
 - a) The time of preheating from 150°C to 200°C shall be within maximum 180 seconds;
 - b) The time of soldering temperature at 217°C measured on capacitors' top shall not exceed t_L (second);
 - c) The peak temperature on capacitors' top shall not exceed T_p(°C), and the time within 5°C of actual peak temperature shall not exceed t_p (second).

B. Classification Reflow Profile

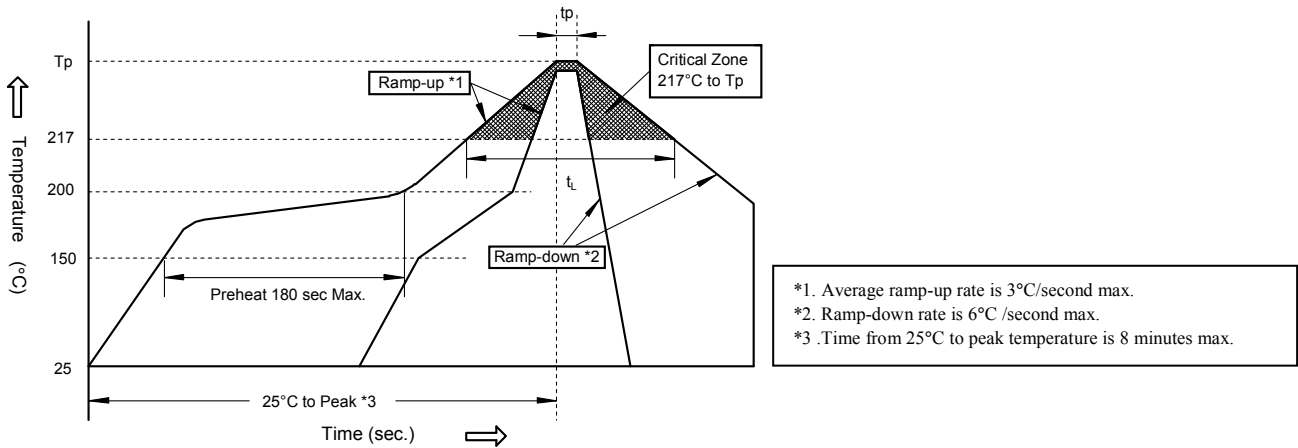

■ Classified at Temperature and Time Only for Standard Size without ()

Size	Thickness (mm)	Volume (mm ³)	T _p (°C)	t _L (second)	T _p (second)
Ø4~Ø6.3 Ø8×6.2L	≥2.5	<350	255±0	60	5
Ø8×10.5L	≥2.5	350~2000	250±0	60	5
Ø10×10.5L/12.5L	≥2.5	350~2000	245±0	60	5
Ø12.5, Ø16	≥2.5	>2000	240±0	40	5

19. Recommended Land Size (Unit: mm)

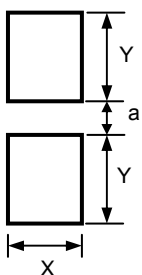

Size	X	Y	a
Ø4	1.6	2.6	1.0
Ø5	1.6	3.0	1.4
Ø6.3	1.6	3.5	2.1
Ø8×6.2L	2.1	4.5	1.6
Ø8×10.5L	2.5	3.5	3.0
Ø10	2.5	4.0	4.0
Ø12.5	3.0	5.7	4.0
Ø16	3.5	6.5	6.0

20. Explanation of Part Number

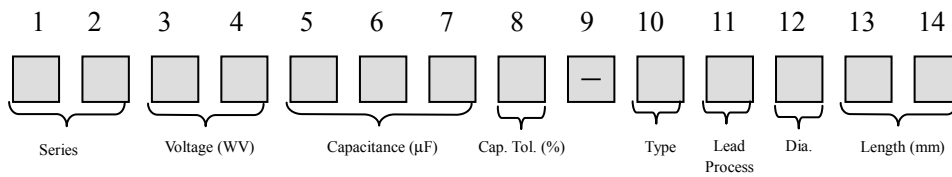

Example: VT 1E 470 M - C R D 54

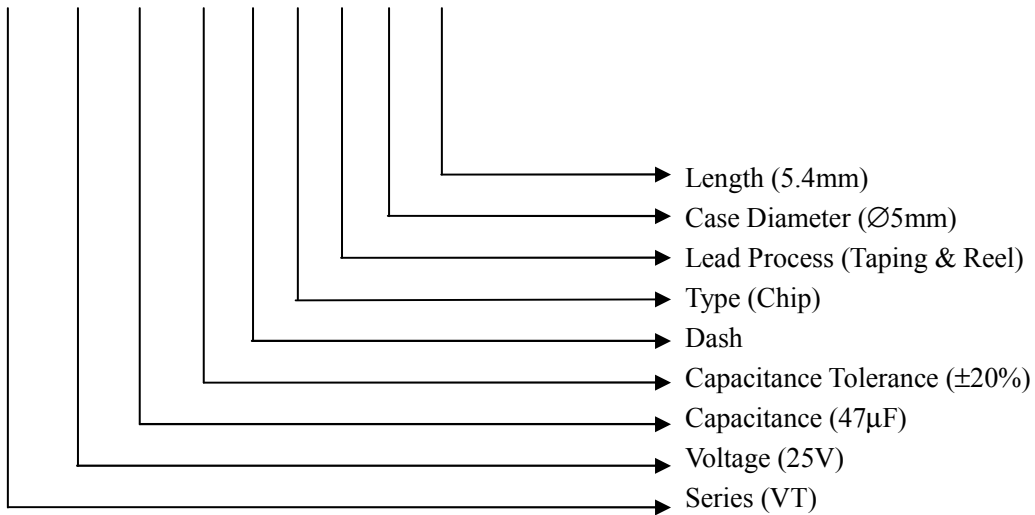

21. Construction

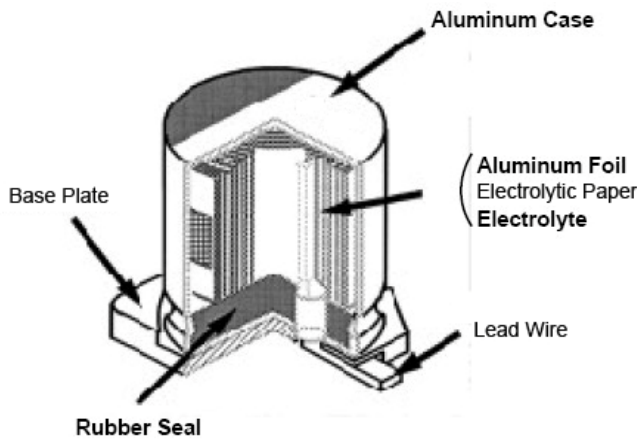

22. Frequency Coefficient of Allowable Ripple Current

Frequency		50Hz	120Hz	300Hz	1KHz	10KHz~	
Coefficient	Ø4 ~ Ø10	0.1 ~ 68µF	0.70	1.00	1.17	1.36	1.50
		100 ~ 3300µF	0.85	1.00	1.08	1.20	1.30
	Ø12.5 ~ Ø16	~ 68µF	0.75	1.00	1.35	1.57	2.00
		100 ~ 680µF	0.80	1.00	1.23	1.34	1.50
		1000 ~ 6800µF	0.85	1.00	1.10	1.13	1.15

23. Dimensions & Maximum Permissible Ripple Current

Part Number	Customer P/N	Capacitance (µF)	Working Voltage (V)	Case Size ØD×L (mm)	Ripple current (Ma rms) at 105°C, 120Hz
VT1E470M-CRD54	/	47	25	5×5.4	32
VT1E221M-CRE77	/	220	25	6.3×7.7	110

24. General Information for Application

The following precautions must be observed when using electrolytic capacitors.

A) Circuit Design

- 1) Please make sure that the environmental and mounting conditions to which the capacitor to be exposed are within the conditions specified in this catalogue.
- 2) Operating temperature and applied ripple must be within the specifications.
 - ① The capacitor shall not be used in an ambient temperature which exceeds the operating temperature specified in the specification.
 - ② Do not apply excessive current which exceeds the allowable ripple current.
- 3) Appropriate capacitors which comply with the life requirement of the products, should be selected when designing the circuit.
- 4) Aluminum electrolytic capacitors are polarized. Make sure that no reverse voltage or AC voltage is applied to the capacitors. Please use non-polarized capacitors for a circuit that can possibly see reserved polarity. Note: Even non-polarizes capacitors cannot be used for AC voltage application.
- 5) For a circuit that repeats rapid charging/discharging of electricity, an appropriate capacitor that is capable of enduring such a condition must be used. Welding machines and photo flash are a few examples of products that contain such a circuit.

For appropriate choice of capacitors for circuit that repeat rapid charging/discharging, please consult us.

- 6) Make sure that no excess voltage (that is higher than the rated voltage) is applied to the capacitor.
 - ① Please pay attention so that the peak voltage, which is DC voltage overlapped by ripple current, should not exceed the rated voltage.
 - ② In the case where more than two aluminum electrolytic capacitors are used in series, please make sure that applied voltage should be lower than rated voltage should be applied to each capacitor equally using a balancing resistor in parallel with the capacitor.
- 7) Outer sleeved of the capacitor is not guarantee as an electrical insulator. Do not use standard sleeve on a capacitor in applications that require electrical insulation. When the application requires special insulation, please contact our sales office for details.
- 8) Capacitors may fail if they are used under the following conditions:
 - ① Environmental (climatic) conditions
 - (a) Being exposed to water, high temperature & high humidity atmosphere, or condensation of moisture.
 - (b) Being exposed to oil or an atmosphere that is filled with particles of oil.
 - (c) Being exposed to salty water or an atmosphere that is filled with particles of salt.
 - (d) In an atmosphere filled with toxic gasses (such as hydrogen sulfide, sulfurous acid, nitrous acid, chlorine, bromine, methyl bromide, ammonia, etc.).
 - (e) Being exposed to direct sunlight, ozone, ultraviolet ray, or radication.
 - (f) Being exposed to acidic or alkaline solutions.
 - ② Severe vibration and physical shock conditions that exceed our specification.

Vibration test condition:

- Vibration frequency range: 10~55~10Hz
- Sweet rate : 10~55~10Hz per minute
- Sweet method : logarithmic
- Amplitude or acceleration : 1.5mm (maximum acceleration is 10G)
- Direction of vibration : X, Y, Z direction
- Testing time : 2 hours per each direction

Shock is not applicable normally.

If a particular condition is required, please contact our sales office.

- 9) When designing a circuit board, please pay attention to the following:

- ① Have the hole spacing on the P.C. board match the lead spacing of the capacitor.
- ② There should not be any circuit pattern or circuit wire above the capacitor safety vent.
- ③ Unless otherwise specified, following clearance should be made above the pressure relief vent.

Case Diameter	Clearance Required
Ø6.3 to 16	2mm or more
Ø18 to 35	3mm or more
Ø40 or more	5mm or more

- ④ In case the vent side is placed toward P.C. board (such as end seal vented parts), make a corresponding hole on the P.C. board to release the gas when vent is

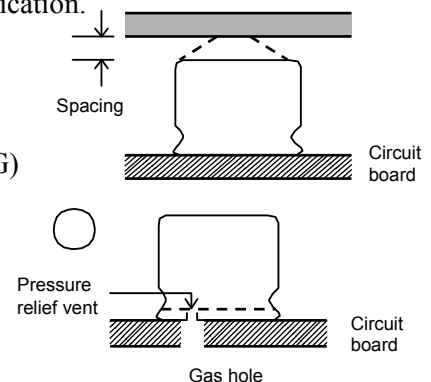

operated. The hole should be made to match the capacitor vent position.

- 10) The main chemical solution of the electrolyte and the separator paper in the capacitor are combustible. The electrolyte is conductive. When it comes in contact with the P.C. board, there is a possibility of pattern or short circuit between the circuit pattern, which could result in smoking or fire. Do not locate any circuit pattern beneath the capacitor end seal.
- 11) Do not design a circuit board so that heat generating components are placed near an aluminum electrolytic capacitor or reserve side of P.C. board (under the capacitor).
- 12) Please refer to the recommended land size in this catalogue when you design in surface mount capacitors.
- 13) Electrical characteristics may vary depending on changes in temperature and frequency. Please consider the variation when you design circuits.
- 14) When you install more than 2 capacitors in parallel, consider the balance of current following in to the capacitor.
- 15) While mounting capacitors on double side P.C. board, the capacitors should be away from those unnecessary base plate holes and connection holes.

B) Mounting

- 1) Once a capacitor has been assembled in the set and power applied, do not attempt to re-use the capacitor in other circuits or application.
- 2) Electric potential between positive and negative terminal may exist as a result of returned electromotive force, so please discharge the capacitor using 1K Ω resistor.
- 3) Leakage current of the parts that have stored for more than 2 years may increase. When leakage current has increased, please perform a voltage treatment using a 1K Ω resistor.
- 4) Please confirm rating and polarity before installing capacitor on the P.C. board.
- 5) Do not drop the capacitors on the floor, nor use a capacitors that was dropped.
- 6) Be careful not to deform the capacitor during installation.
- 7) Please confirm that the lead spacing of the capacitor matches the pad spacing of the P.C. board prior to installation.
- 8) Please pay attention that the clinch force is not too strong when capacitors are placed and fixed by an automatic insertion machine.
- 9) Please pay attention to the mechanical shock to the capacitor by suction nozzle of the automatic insertion machine or automatic mounted, or by product checker, or by centering mechanism.
- 10) Hand soldering:
 - ① Soldering condition shall be confirmed to be within the specification.
 - ② If it is necessary that the leads must be formed due to a mismatch of the lead space to hole space on the board, bend the lead prior to soldering without applying too much stress to the capacitor.
 - ③ If you need to remove parts which were soldered, please melt the solder enough so that stress is not applied to lead.
 - ④ Please pay attention so that solder iron does not touch any portion of capacitor body.
- 11) Flow soldering (wave solder):
 - ① Aluminum capacitor body must not be submerged into the solder bath.
 - ② Soldering condition must be confirmed to be within specification.
 - ③ Please avoid having flux adhere to any portion except the terminal.
 - ④ Please avoid contact between other components and the aluminum capacitor.
- 12) Reflow soldering (SMD only):
 - ① Please follow "Reflow Soldering Conditions" in this catalogue.
 - ② When an infrared heater is used, please pay attention to the extent of heating since the absorption rate of infrared, will vary due to difference in the color and size of the capacitor.
- 13) Do not tilt lay down or twist the capacitor body after the capacitor are soldered to the P.C. board.
- 14) Do not carry the P.C. board by grasping the soldered capacitor.
- 15) Please do not allow anytime to touch the capacitor after soldering. If P.C. board are stored in stack, please make sure P.C. board or the other components do not touch the capacitor. The capacitors shall not be effected by any radiated heat from the soldered P.C. board or other components after soldering.
- 16) Cleaning
 - ① Do not clean capacitors with halogenated cleaning agent. However, if it is necessary to clean with halogenated cleaning agent, please contact our sales office.
 - ② Recommended cleaning method:
Applicable: Any type, any ratings.
Cleaning agents:
Based alcohol solvent cleaning agent: Isopropyl Alcohol
Based water solvent cleaning agent:
Premium alcohol solvent type: Pine Alpha ST-100S, Techno Care FRW14~17, Sanelek B-12

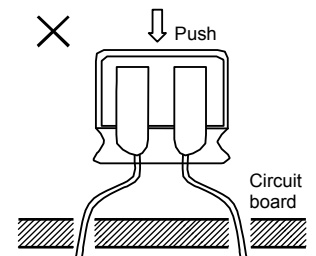

Surfactant type: cleaning through 750H/750L/710M

Alkaline saponification agent: Aqua Cleaner 210SEP

Cleaning conditions:

Total cleaning time shall be within 5 minutes by immersion, ultrasonic or other method. Temperature of the cleaning agent shall be 60°C or lower. After cleaning, capacitors should be dried using hot air for minimum of 10 minutes along with the P.C. board. Hot air temperature should be below the maximum operating temperature of the capacitor. Insufficient dry after water rinse may cause appearance problems, sleeve shirk, bottom-plate bulge and such.

③ Avoid using ozone destructive substance for cleaning agents to concern about global environment.

17) Fixing Material and Coating Material

① Do not use any affixing or coating materials, which contain halide substance.

② Remove flux and any contamination, which remains in the gap between the end seal and P.C. board.

③ Please dry the cleaning agent on the P.C. board before using affixing or coating materials.

④ Please do not apply any material all around the end seal when using affixing or coating materials.

There are variations of cleaning agents, fixing and coating materials, so please contact those manufacture or our sales office to make sure that the material would not cause any problems.

18) Other

Wooden package material may be subjected to fumigation by a halogen (e.g. methyl bromide) before they are exported in order to protect them against pests. If devices with aluminum electrolytic capacitors or capacitors themselves are directly fumigated or packed with the pallet that is fumigated, the capacitors may internally corrode due to the halogen contents of fumigation agents.

C) In The Equipment

1) Do not directly touch terminal by hand.

2) Do not short between terminal by conductor, nor spill conductible liquid such as alkaline or acidic solution on or near the capacitor.

3) Please make sure that the ambient conditions where the set is installed not have any of the following conditions:

① Where capacitors are exposed to water, high temperature & high humidity atmosphere, or condensation of moisture.

② Where capacitors are exposed to oil or an atmosphere that is filled with particles of oil.

③ Where capacitors are exposed to salty water, high temperature & high humidity atmosphere, or condensation of moisture.

④ The atmosphere is filled with toxic acid gasses (e.g. hydrogen sulfide, sulfurous acid, nitrous acid, chlorine, bromine, methy bromide, etc.).

⑤ The atmosphere is filled with toxic alkaline gasses (e.g. ammonia).

⑥ Where capacitors are exposed to acidic or alkaline solutions.

⑦ Since shrinkage, bulging and/or crack could be seen on outer sleeve of capacitor when capacitors are used in atmosphere where condensation of moisture occurs, please confirm their adaptation before the use. The condensation of moisture could occur when temperature cycling test/rapid change of temperature test is performed, in this case, aforementioned sleeve problem could be seen.

D) Maintenance and Inspection

Please periodically inspect the aluminum capacitors that are installed in industrial equipment. The following items should be checked:

1) Appearance: Remarkable abnormality such as vent operation, leaking electrolyte etc.

2) Electrical characteristic: Capacitance, dielectric loss tangent, leakage current etc., which are specified in this catalogue.

E) In an Emergency

1) If you see smoke due to operation of safety vent, turn off the main switch or pull out the plug from the outlet.

2) Do not draw your face to the safety vent since gas over 100°C will be emitted when the safety vent operates. If the gas has entered your eyes, please flush your eyes immediately in pure water. If you breathed the gas immediately wash out your mouth and throat with water.

3) Do not ingest electrolyte. If your skin is exposed to electrolyte, please wash it away using soap and water.

F) Storage

1) Do not keep capacitor in high temperature and high humidity.

Storage conditions should be:

Temperature : +5°C ~ +35°C

Humidity : Lower than 75%

Place : Indoor

- 2) Avoid ambient conditions where capacitors can be covered with water, brine or oil.
- 3) Avoid ambient conditions where capacitors are exposed to poisonous gases such as hydrogen sulfide, sulfurous acid, nitrous acid, chlorine, ammonium etc.
- 4) Do not keep capacitor in conditions that expose the capacitor to ozone, ultraviolet ray or radiation.
- 5) Store capacitors in a packed condition as much as possible.

G) Disposal

- 1) Please dispose capacitors in either of the following ways:
 - ① Incinerate (at a temperature of 800°C or higher) capacitors after crushing parts or making a hole on the capacitor body.
 - ② If incineration is not applicable, hand them over to a waste disposal agent and have them buried in a landfill.
- 2) When removing a capacitor from the circuit board or when disposing of capacitor please ensure that the capacitor is properly discharged.

25. Other

- 1) All design and specifications are for reference only and is subject to change without prior notice. If any doubt about safety for your application, please contact us immediately for technical assistance before purchase.
- 2) **Commitment Not To Use The Hazardous Substances.**

Our company guaranty: The products or components supplied by us either direct trade or through the third party trade, all are met environmental protection requirement, In case any products from our company is found the substances contained higher than the following standards, so causing your customer complaints or compensation request our company will be responsible for all the consequences. The material changes stipulate by the law shall be notified to the customer in writing. Please refer to our third party environmental material test report for details.

NO.	Prohibited Substances	content
1	Cd	N.D
2	Pb	<50PPM
3	Hg	N.D
4	Cr VI	N.D
5	PBB	N.D
6	PBDE	N.D
7	DBP	N.D
8	BBP	N.D
9	DEHP	N.D
10	DIBP	N.D
11	SVHC	N.D